

Wheel Type Incremental Rotary Encoder

■ Features

- Suitable for measuring the length or speed of target moving successively by wheel type
- The output waveform according to measuring distance is proportional to the unit of International Measurement type (meter or inch)
- Power supply: 5VDC, 12-24VDC ±5%

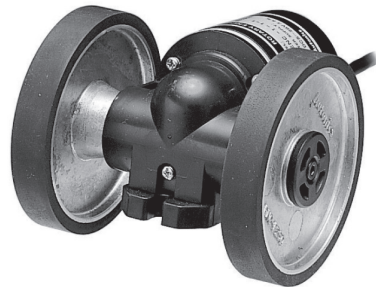

■ Applications

- Various packing machine, sheet manufacturing, textile machinery, and general industrial machinery etc.

⚠ Please read "Safety Considerations" in the instruction manual before using.



■ Ordering Information

ENC	-	1	-	1	-	N	-	24	-	
Series	Output phase	Min. measuring unit		Control output		Power supply		Cable		
Wheel type	1: A, B	1: 1mm 2: 1cm 3: 1m	4: 0.01yd 5: 0.1yd 6: 1yd	T: Totem pole output N: NPN open collector output V: Voltage output		5: 5VDC ±5% 24: 12-24VDC ±5%		No mark: Axial cable type C: Axial cable connector type		

■ Specifications

Item		Wheel Type Incremental Rotary Encoder		
Min. measuring unit		1mm/pulse, 1cm/pulse, 1m/pulse, 0.01yd/pulse, 0.1yd/pulse, 1yd/pulse		
Electrical specification	Output phase	A, B phase		
	Phase difference of output	Phase difference between A and B : $\frac{T}{4} \pm \frac{T}{8}$ (T=1cycle of A phase)		
	Control output	Totem pole output	• [Low] - Load current: max. 30mA, residual voltage: max. 0.4VDC≒ • [High] - Load current: max. 10mA, output voltage (power voltage 5VDC≒): min. (power voltage-2.0)VDC≒, output voltage (power voltage 12-24VDC≒): min. (power voltage-3.0)VDC≒	
		NPN open collector output	Load current: max. 30mA, residual voltage: max. 0.4VDC≒	
		Voltage output	Load current: max. 10mA, residual voltage: max. 0.4VDC≒	
	Response time (rise/fall)	Totem pole output	Max. 1μs (cable length: 2m, I sink = 20mA)	
		NPN open collector output		
		Voltage output		
	Max. response frequency	180kHz		
	Power supply	• 5VDC≒ ±5% (ripple P-P: max. 5%) • 12-24VDC≒ ±5% (ripple P-P: max. 5%)		
Current consumption	Max. 80mA (disconnection of the load)			
Insulation resistance	Over 100MΩ (at 500VDC megger between all terminals and case)			
Dielectric strength	750VAC 50/60Hz for 1 minute (between all terminals and case)			
Connection	Axial cable type, Axial cable connector type			
Mechanical specification	Starting torque	Depend on coefficient of friction		
	Max. allowable revolution ^{※1}	5,000rpm		
Vibration	1.5mm amplitude at frequency of 10 to 55Hz (for 1 min) in each X, Y, Z direction for 2 hours			
Shock	Approx. max. 75G			
Environment	Ambient temperature	-10 to 70°C (at non-freezing status), storage: -25 to 85°C		
	Ambient humidity	35 to 85%RH, storage: 35 to 90%RH		
Cable	Axial cable type	Ø5mm, 4-wire, 2m, Shield cable (AWG24, core diameter: 0.08mm, number of cores: 40, insulator out diameter: Ø1mm)		
	Axial cable connector type	Ø5mm, 5-wire, 250mm, Shield cable (AWG24, core diameter: 0.08mm, number of cores: 40, insulator out diameter: Ø1mm)		
Protection structure	IP50 (IEC standard)			
Approval	CE			
Unit weight	Approx. 494g			

※1: Make sure that max. response revolution should be lower than or equal to max. allowable revolution when selecting the resolution.

$$[\text{Max. response revolution (rpm)}] = \frac{\text{Max. response frequency}}{\text{Resolution}} \times 60 \text{ sec}$$

※Environment resistance is rated at no freezing or condensation.

SENSORS
CONTROLLERS
MOTION DEVICES
SOFTWARE

(A) Photoelectric Sensors
(B) Fiber Optic Sensors
(C) LIDAR
(D) Door/Area Sensors
(E) Vision Sensors
(F) Proximity Sensors
(G) Pressure Sensors
(H) Rotary Encoders
(I) Connectors/ Connector Cables/ Sensor Distribution Boxes/ Sockets

ENC Series

Control Output Diagram

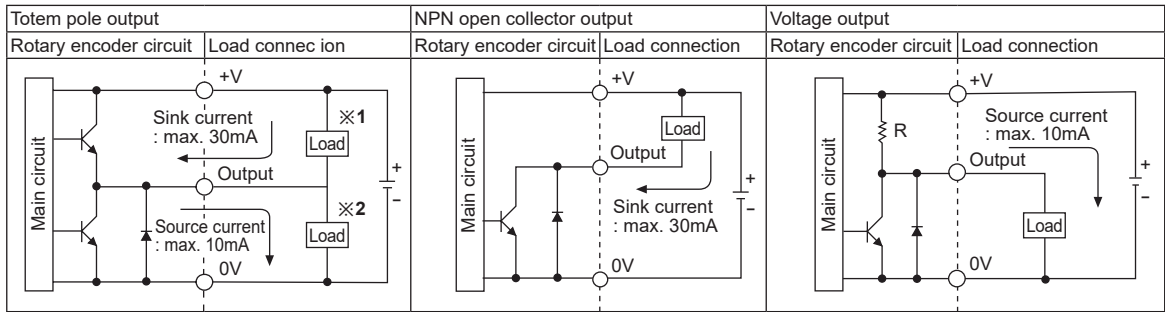

- The output circuits of A, B phase are same.
- Totem pole output type can be used for NPN open collector type (※1) or voltage output type (※2).

Output Waveform

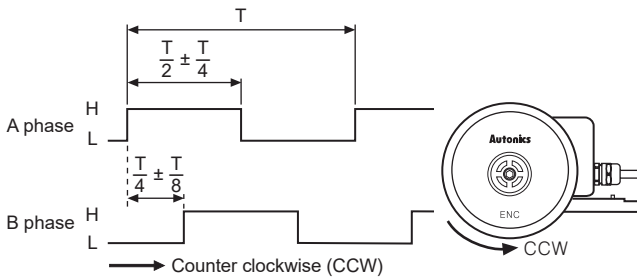

Resolution

Wheel circumference	No.※1	No. of encoder pulse	Gear ratio	Min. measuring unit
250mm	1	250-pulse	1:1	1mm/pulse
	2	100-pulse	4:1	1cm/pulse
	3	1-pulse	4:1	1m/pulse
228.6mm (0.25/yd)	4	100-pulse	4:1	0.01yd/pulse
	5	10-pulse	4:1	0.1yd/pulse
	6	1-pulse	4:1	1yd/pulse

※1: This table is for the numbers which represents 'min. measuring unit' in model name.

Connections

◎ Axial cable type

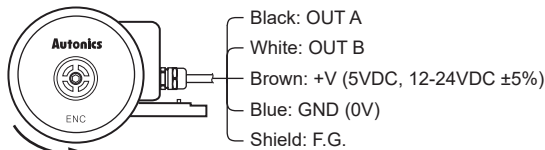

Counter clockwise (CCW)

- ※Unused wires must be insulated.
- ※The metal case and shield wire of encoder must be grounded (F.G.)
- ※Do not apply tensile strength over 30N to the cable.

◎ Axial cable connector type

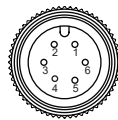

Pin No	Cable color	Function
①	Black	OUT A
②	White	OUT B
③	Orange	N-C
④	Brown	+V
⑤	Blue	GND
⑥	Shield	F.G.

※F.G. (field ground)
: It must be grounded separately.

Dimensions

(unit: mm)

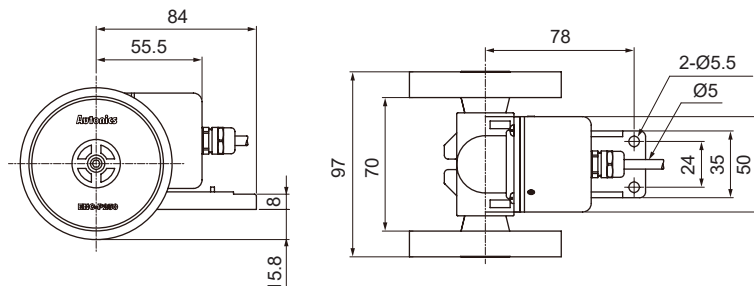

Cable for axial cable type
Ø5mm, 4-wire, Length: 2m, Shield cable
Cable for axial cable connector type
Ø5mm, 5-wire, Length: 250mm, Shield cable

- ※The wheel circumference(Ø) is changed according to model, please refer to resolution chart.
- ※Connector cable is sold separately and refer to the 'Connectors, Connector Cables, Sensor Distribution Boxes, Sockets' section.